

Crew Compartment - Requires Crew of Four Minimum - Rotates With A/C Angle of Attack and Heading

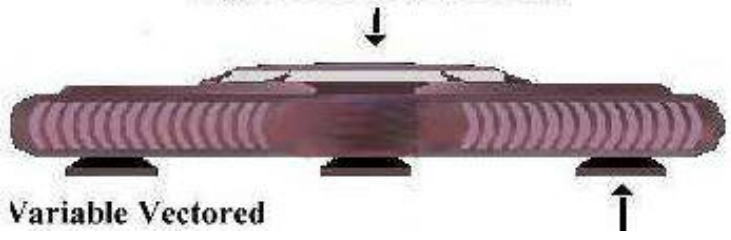

The Case For Antigravity

Always CHECKTHEEVIDENCE.COM

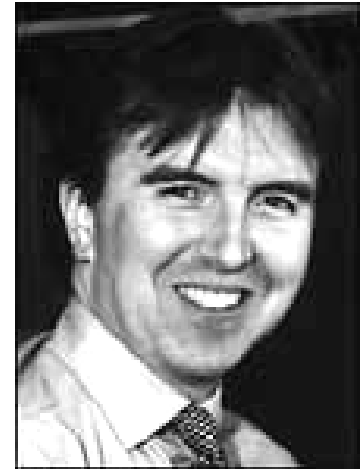
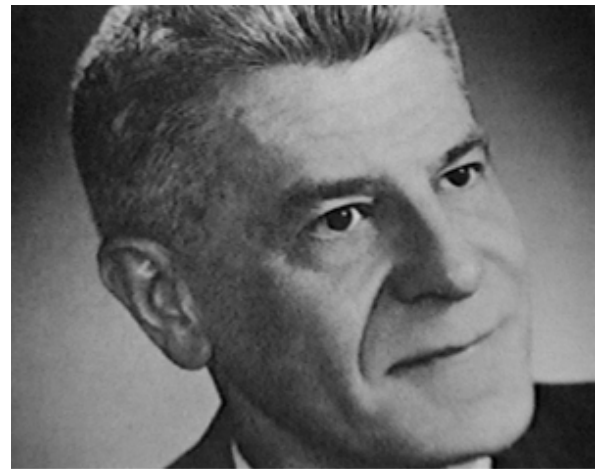
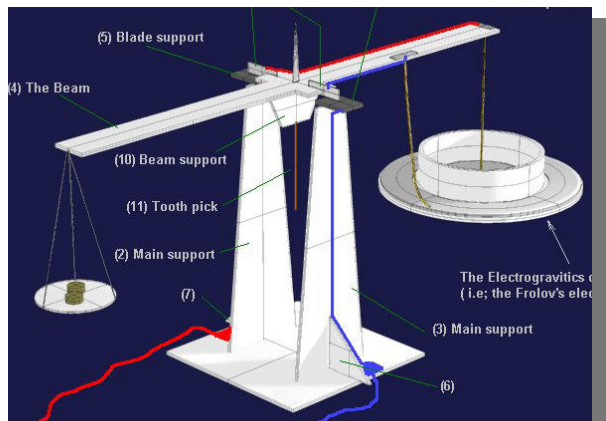

Introduction

- Basic Questions:
 - ◆ What is Gravity?
 - ◆ What is Anti-Gravity?
 - ◆ What evidence is there that technology, other than “conventional” aerospace technology exists which could be thought of as being “Anti-Gravity” or something attempting to control Gravity?
- We will look at:
 - ◆ Some of the history of Antigravity Research
 - ◆ Some of the Research of Nick Cook
 - ◆ The Hutchison Effect
 - ◆ Some Antigravity Experiments
 - ◆ Coral Castle (Florida)
 - ◆ Alleged Black Projects in the USA
 - ◆ Sightings of Flying Triangles
 - ◆ Hints of “New Technology” which have come from NASA

What is Gravity 1?

- **Newtonian theory says:**
 - ◆ “gravity, Force of attraction that arises between objects by virtue of their masses.” (*Chambers English Dictionary – CD ROM edition 1996*)
 - ◆ The force of gravity obeys an “inverse square law” – at twice a given distance, the force is only 1 quarter as strong.

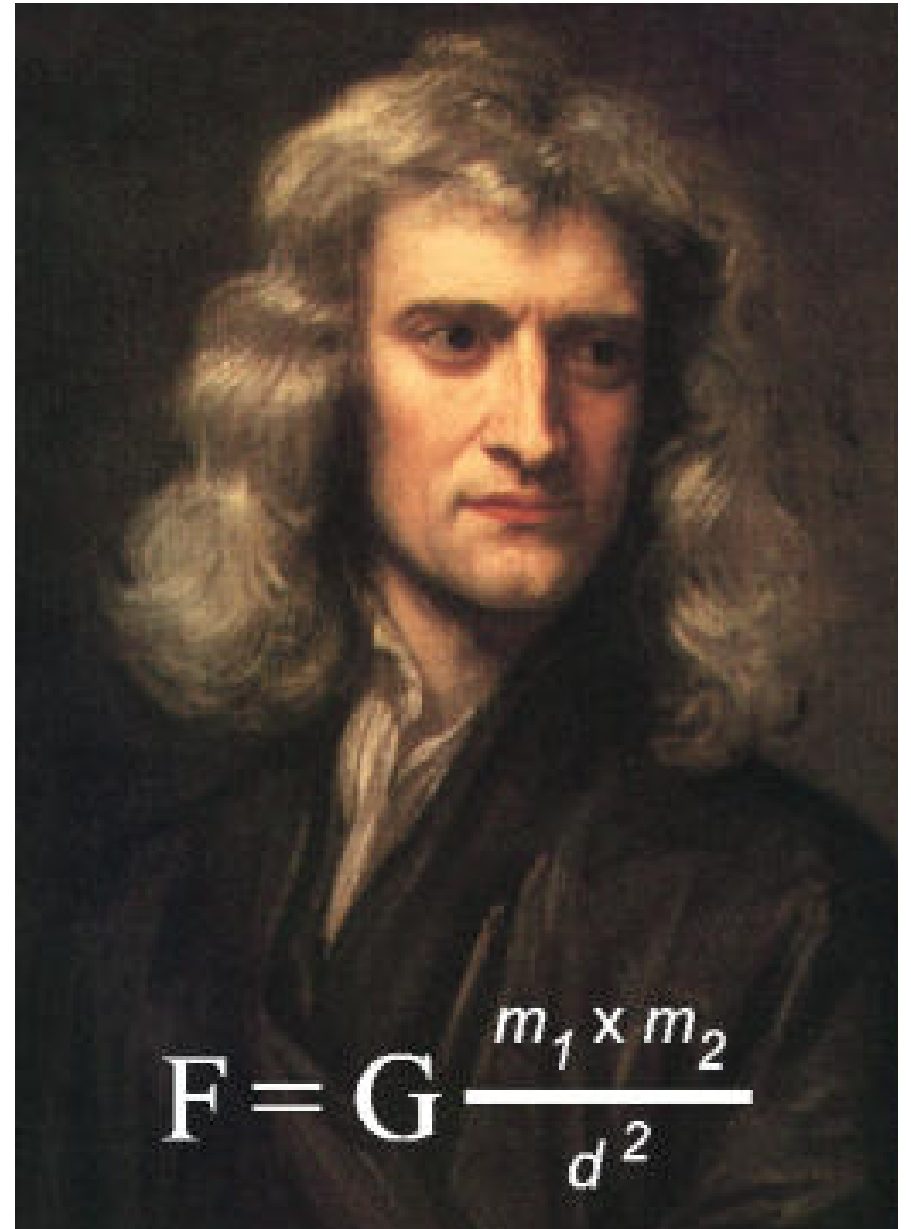

What is Gravity 2?

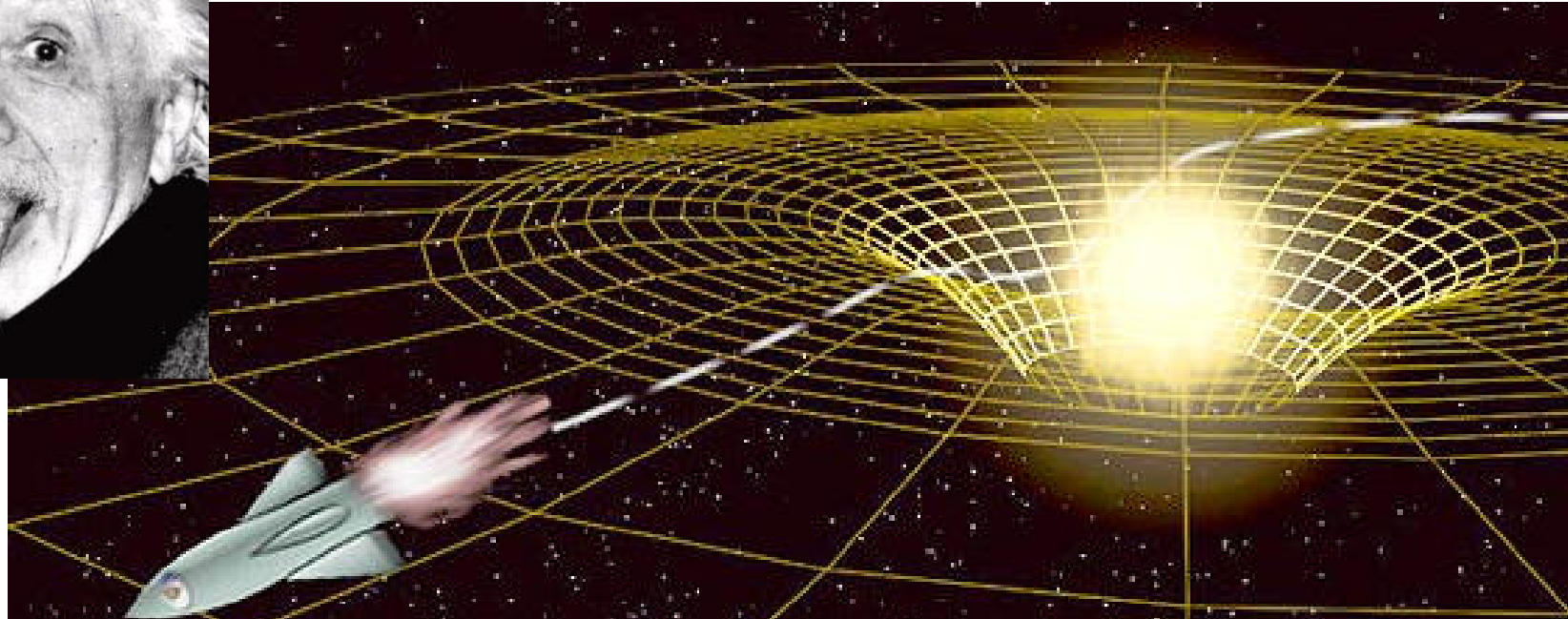
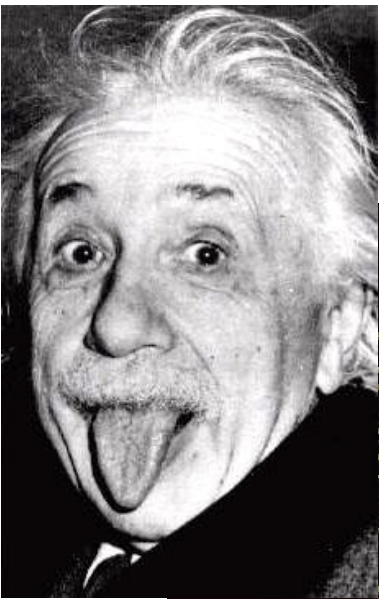

- *Einsteinian Gravity (Relativity)*

- ◆ *A planet's orbit around the Sun (as observed in three-dimensional space) arises from its natural trajectory in modified space-time; there is no need for a force of gravity coming from the Sun and acting on the planet. This explains oddities in the orbit of Mercury (the precession of the Perihelion), not explained by Newtonian Gravitation (Hutchinson's Concise Encyclopaedia, CD-ROM Edition 1996)*

What is Gravity 3?

- Gravity is **WEAK** in comparison to the other forces of nature.
- String theory suggests, then, that:
 - ◆ Gravity may be similar to other forces.
 - ◆ Part of its force acts “in another dimension”.
 - ◆ Alternatively, it may be a force “leaking” from another dimension into our own.
- This could account for it being difficult to measure **G**, the “gravitational constant” accurately (it is given a value of 6.67×10^{-11}).
- Though String Theory seems to be the most popular as a way of explaining Gravity, there is another theory called **Loop Quantum Gravity**.
- Does any of this sound like a good explanation of Gravity?

What is NOT Anti-Gravity/An Anti-Gravity Device?

- A chair is NOT an anti-gravity device (by my definition!) simply because it stops you falling down. (A chair is simply a rigid structure which **resists** the force of gravity.)
- A balloon is NOT an anti-gravity device – it floats because of **mass displacement** (Archimedes Principle).
- A Propeller/Jet/Rocket Engine is NOT an anti-gravity device. It works by displacing mass from one place to another to generate thrust.
- An Ion engine is not an Anti-Gravity device – it also works by mass-displacement, but is rather more efficient with propellant mass than Chemical rockets.

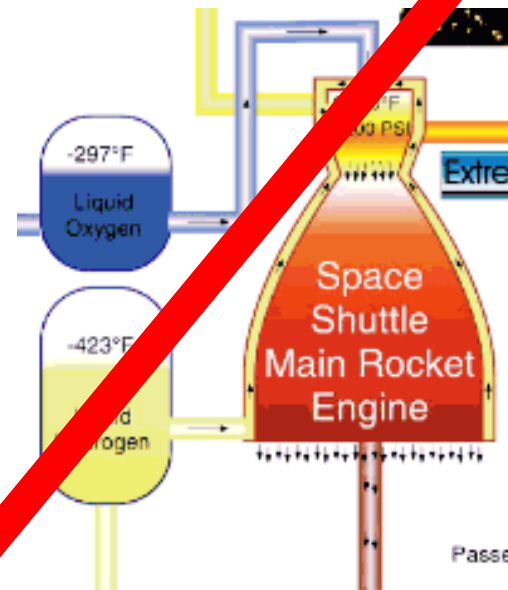
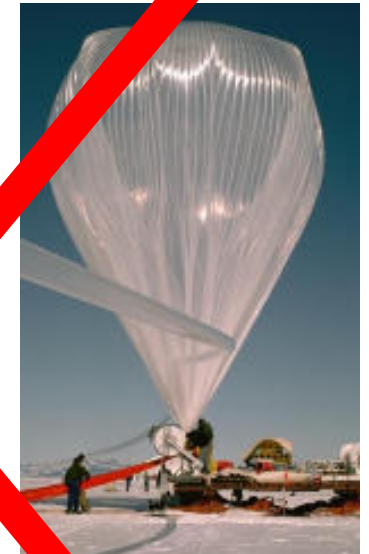
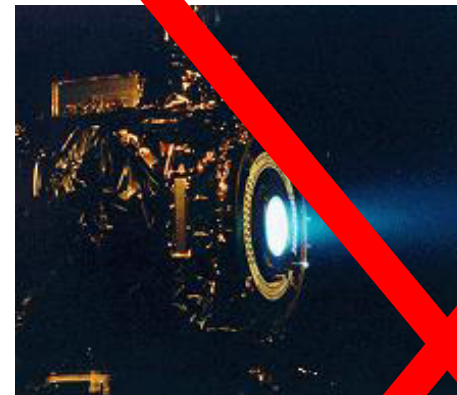
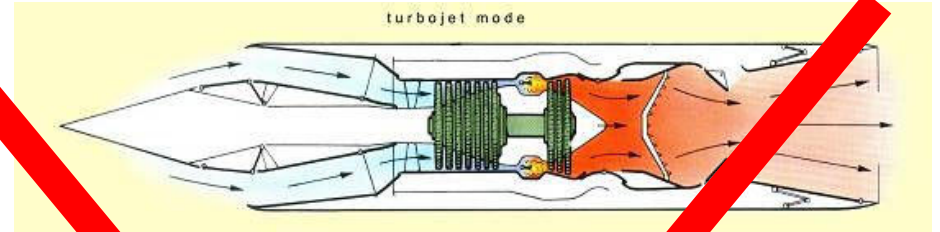

What is Anti-Gravity/An Anti-Gravity Device?

- Any device / method capable of **changing** the *local gravitational field strength* or *having the effect of reducing an object's weight*. (No “propellant”)
- Another term might simply be **Gravity Control**.

TT Brown's Experimental Gravitator Disk

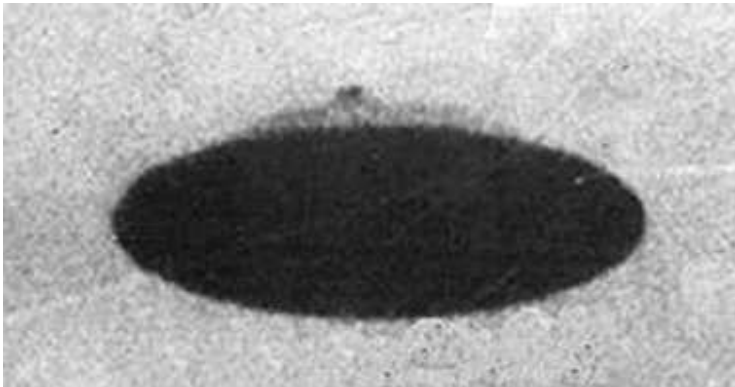

McMinville Saucer (Paul Trent, May 8, 1950)

Lifter 1 – JL Naudin Experimental Model

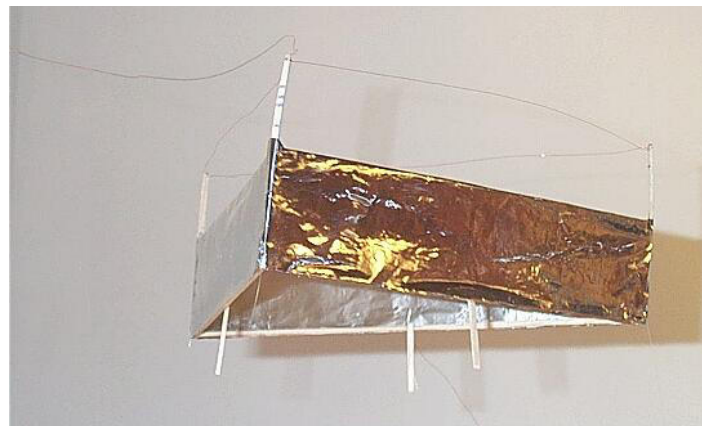

Experimental tri-arcuate ballistic electrode
3 feet in diameter

General Characteristics of Anti-Gravity Devices & Experiments

- When working through Anti-gravity research, several things seem to recur
 - ◆ Devices spinning very quickly or having spinning components at high speed.
 - ◆ Feeding in High Voltage – **Electrogravitics**
 - ◆ Using Strong Magnetic Fields – **Magnetogravitics**
 - ◆ High Frequency Oscillations of Electric Current or Magnetic Field.

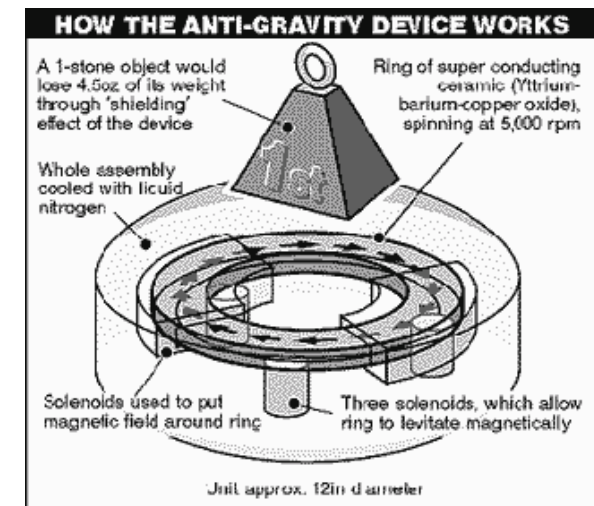

History of Anti-Gravity Research - 1

- This may have even started in the early days of electric power, around 1900.
- According to Nick Cook's research (discussed later), there was open discussion of the subject among groups of scientists until about 1956, when it seemed to become the subject of ridicule and/or went "underground".
- There are many historical, even mythological, figures who have supposedly experimented with gravity control.
- Two prominent names are **Nikola Tesla** and **Thomas Townsend Brown**.

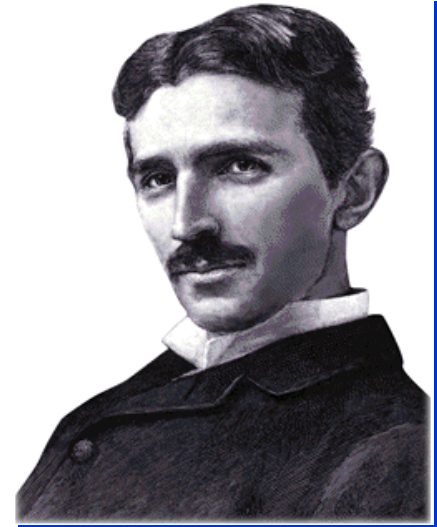

Nikola Tesla (1856-1943)



Thomas Townsend-Brown (1905-1985)

Nikola Tesla

- Tesla was born in Serbia and emigrated to the US in 1884.
- Tesla was mainly a pioneer in the fields of Electrostatics and Electricity Generation (with Thomas Edison) and invented the **Alternating Current**-based electricity distribution system we use today.
- It was his work which paved the way for similar pioneering work in the field of Electrogravitics by people like Brown.
- The unit of **Magnetic Field Flux Density** is named after Tesla.
- It is claimed that Tesla built and operated Over Unity (“energy for nothing”) devices.
- After his death, most of his notes and papers disappeared.
- Many stories about him have also been snowballed in myth and legend, in much the same way as those in the UFO field.



Nikola Tesla (1856-1943)

Thomas Townsend Brown - 1

- Thomas Townsend Brown was born in Ohio.
- Townsend Brown never obtained a degree. He spent time studying at several schools including Caltech, Kenyon College and Denison University.
- He has been called a Physicist but was probably an Electrical Engineer more than anything else.
- He served in the US Navy in the 1930's at the Naval Research Laboratory.
- He was involved in Project Winterhaven – a research proposal to build an Anti Gravity craft, based on the work Townsend Brown had already completed.
- He died in California in 1985.
- Much of his work still seems to be kept “under wraps” and his family keep a low public profile.



Thomas Townsend-
Brown (1905-1985)

Thomas Townsend Brown - 2

- He worked with Dr. Paul Biefeld (friend of Albert Einstein), Director of Swazey Observatory in Denison, Ohio.
- In 1923, they started to experiment with “gravitators” and found an interaction between electric charge and the force of gravity.
- Separate to his study of Physics, Townsend Brown founded NICAP (National Investigations Committee on Aerial Phenomenon) in 1956, to serve as a clearing-house and “listening post” for information regarding Saucer sightings and evidence.
- He served for some time as Director of NICAP (as did Major Donald Keyhoe).

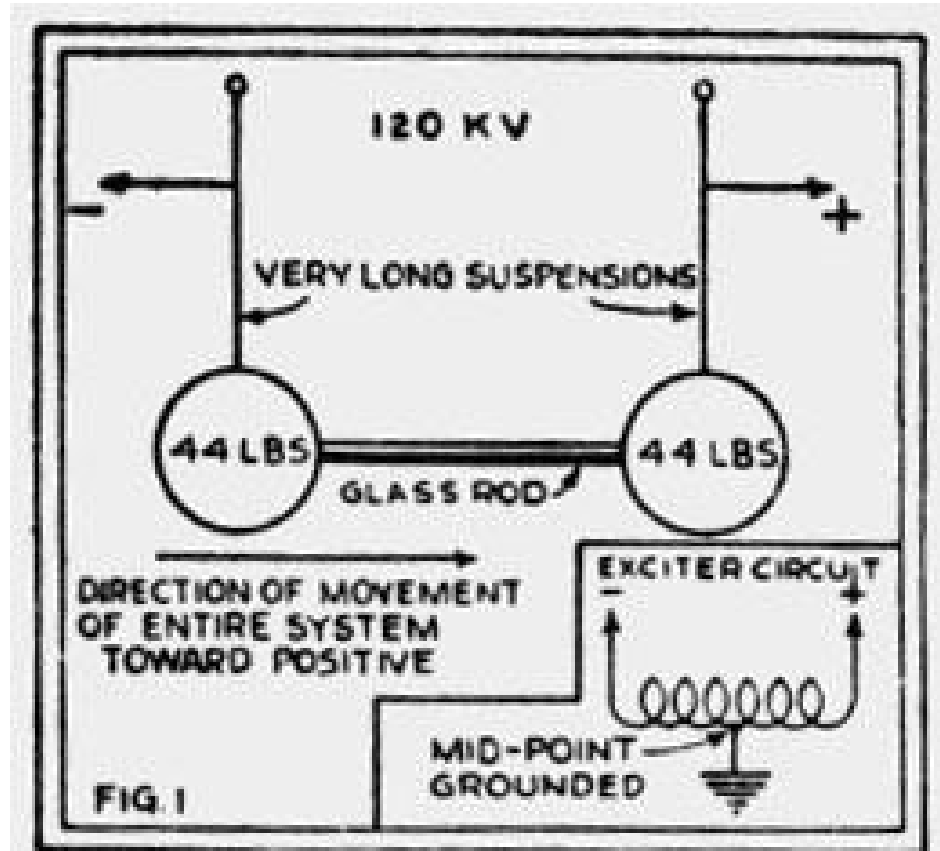

A SIMPLE TYPE OF GRAVITATOR IS SHOWN IN THE ABOVE ILLUSTRATION.

Thomas Townsend Brown - 3

- He worked in a field which has come to be known as **Electro-gravitics**.
- TTB patented a number of his “inventions”
- In the 1950’s, he worked at the Bahnson Lab.
- In a response letter written to an interested person in January 1982, TTB wrote:

“I regret to advise you that electrogravitic research has been taken over in its entirety by a Californian corporation which has imposed secrecy - at least until their investigations are completed”.

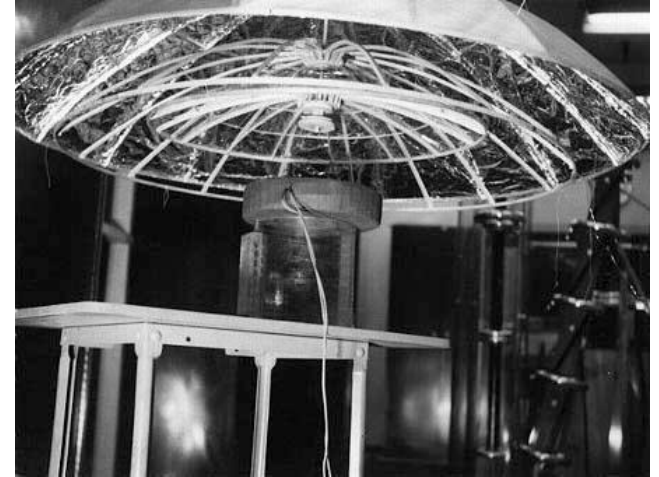

Electrokinetic Apparatus at the Bahnson Lab, January 3, 1958 – 43 inch foil.



Dr Tom Turner, TTB and someone else, April 5, 1958.

The Biefeld-Brown Effect

- This effect was originally discovered when they were working with high voltage X ray tubes – they moved excessively when turned on and off.
- When a Capacitor is Charged up, it **LOSES WEIGHT!**
- Biefeld set Brown to work on the phenomenon
- More on this later...



“The Hunt For Zero Point”

- Nick Cook, journalist and former editor of *Jane's Defence Weekly* became intrigued when someone sent him an article about anti-gravity research.
- He tried to follow up a contact, George S. Trimble, whom, he had read, had worked in the field of anti-gravity research in the 50's.
- Trimble initially agreed to be interviewed, but then withdrew suddenly – reportedly “scared”.
- Cook continued his research “quietly” over 10 years and journeyed some way into the “black world” of defence research during World War II.
- His book “The Hunt For Zero Point” is the story of that journey.
- Here, he talks about some of his findings, initially about American Research.

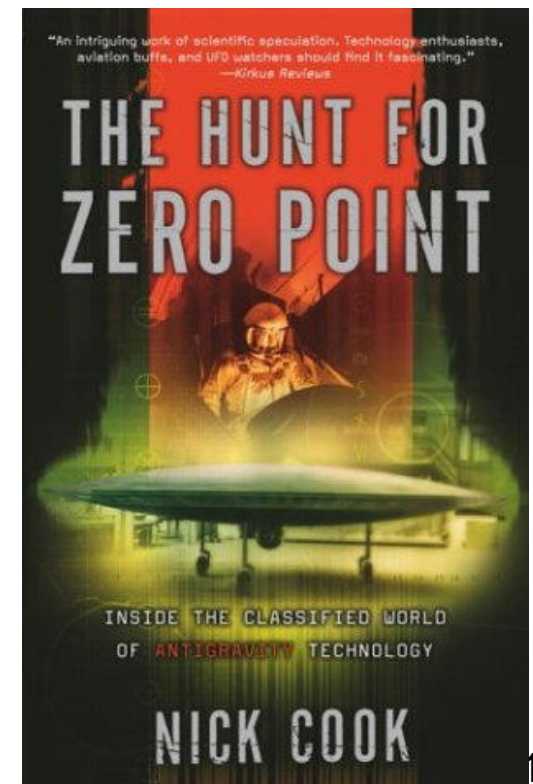
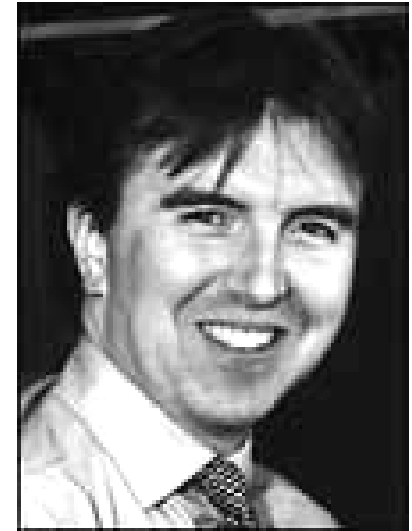

Hans Kamler

- One of the figures Nick Cook encountered during exploring German wartime Anti-Gravity research was Hans Kamler.
- Hans Kamler seemed to have been in charge of Nazi “Black Projects”.
- It is not known what became of Kamler, as there are 4 different accounts of his death, for example.



German Research & “The Bell”

- A number of unusual experiments seemed to have been carried out by the Germans in the 40's e.g. Schauberger's “Repulsine”, which was an over-unity implosion device, possibly similar to the Hydrosonic Pump, but Schauberger reported his actually lifted off during testing.
- One of the experiments Nick Cook found some evidence of was **The Bell**. It was conducted in a mine in what is now Poland (but was Germany in WW II).
- As with similar experiments, it had components rotating at very high speed and it has been said that this would have the bizarre effect of “influencing the space-time field”.
- This seems to be a recurrent theme – and such experiments are often said to produce anomalous energy or field effects – much like those observed near Flying Saucers.

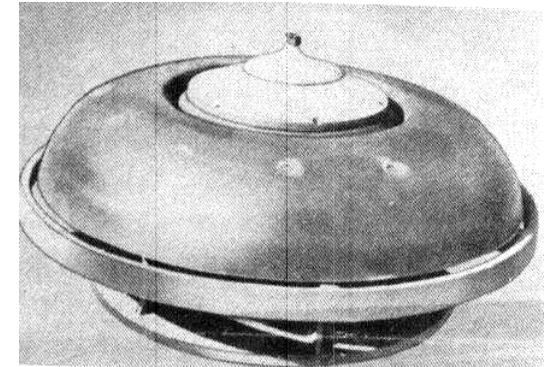

Repulsine - 1



Artist's
impression of
“the Bell”

The Biefeld-Brown Effect - 2

- Capacitor-weighing Balance (Jean Louis Naudin).



Schematic of Capacitor-weighing Balance

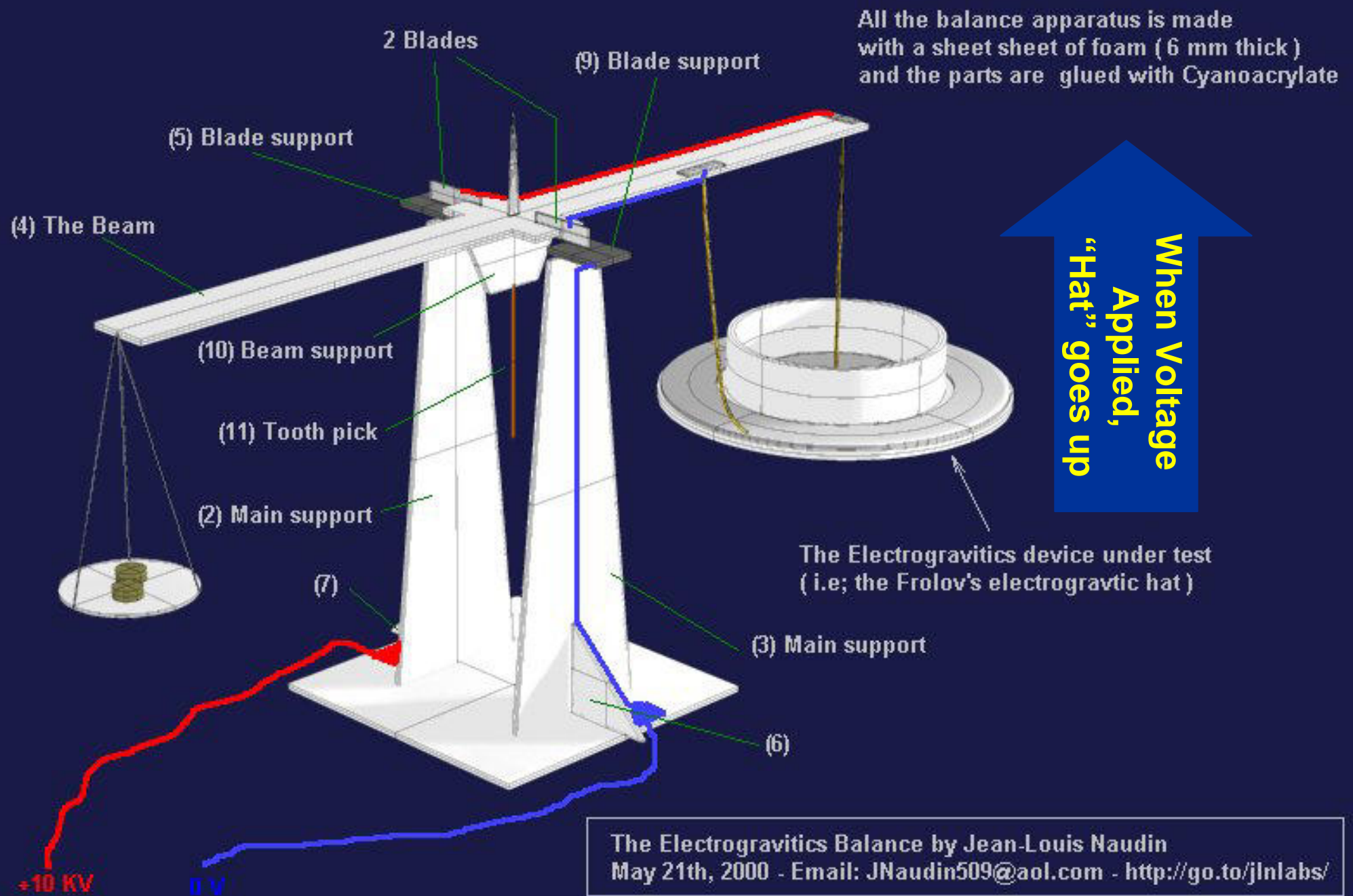

Capacitor in Plastic Bag...

- The Ion Wind explanation seems less likely to be correct when you see the experiment operating inside a plastic bag...



The Biefeld-Brown Effect - 5

- Many scientists say that there is no electro-gravitic effect – it is a by-product of air ionisation or an “ion-wind”
- However, calculations seem to show that “Ion Wind” alone is not enough to account for the amount of lift/thrust produced.
- With the Electric Balance, the Ion Wind should cease when the power is switched off (I think), but the balance levels as the capacitor discharges.
- It is fairly easy to build a **Lifter... using a High Tension source (old TV), Balsa Wood and Aluminium Foil**

Lifter 1

Lifter1
construction
by JL Naudin

STEP#3

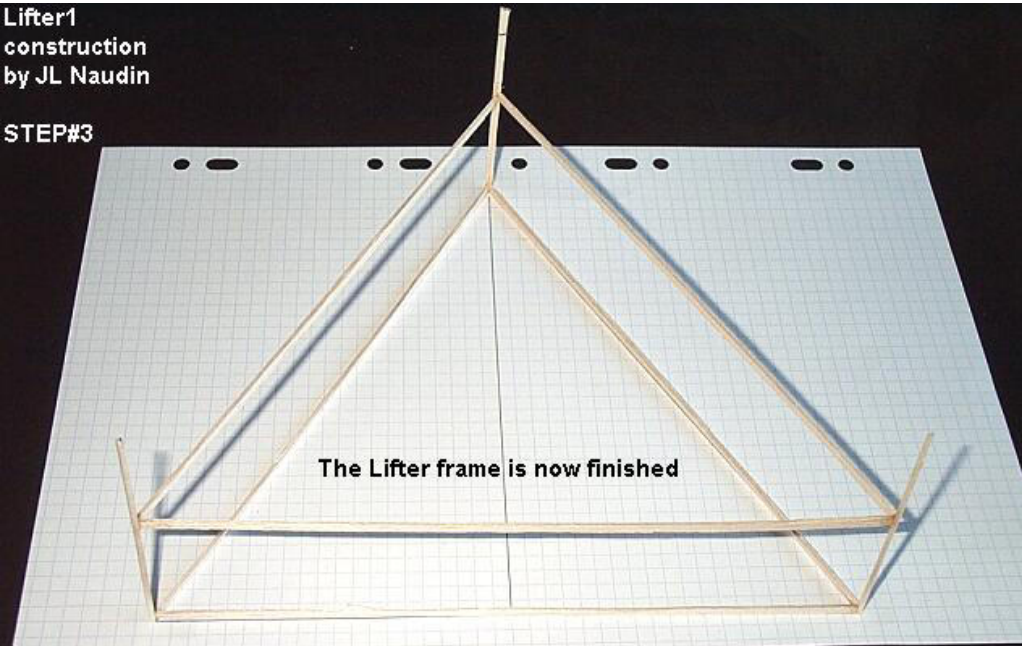

STEP#4

The Lifter1 construction by JL Naudin

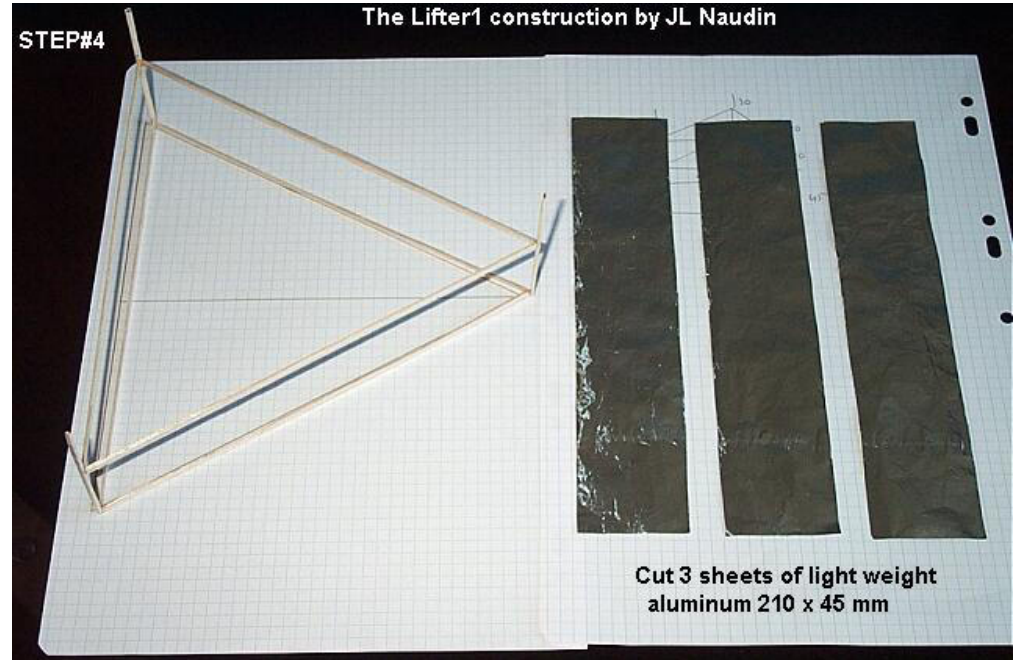

Lifter1 construction by JL Naudin

STEP#5

<http://jnaudin.free.fr/html/lftbld.htm>



Lifter1 construction by JL Naudin

STEP#7



The Hutchison Effect - 1

- This the name given to what appeared in the video clip with Boyd Bushman & Nick Cook (which some say is just a fraud).
- Bushman hinted to Nick Cook he should take a trip to Vancouver to see John Hutchison – the person who did the “tricks” in the video.
- Hutchison can produce this effect with between 75 W and 1.5 kW of power.
- In November 2008, he reproduced the levitation effect as part of a “challenge”.
- Melting and Fusion of metals also seems to be an occasional side effect – as shown in the photo (right).



The Hutchison Effect - 2

- John Hutchison's Lab Equipment was confiscated on 24 February 1990 by the direct order of former Canadian Prime Minister Brian Mulroney. The Government has retained the lab in spite of a court order by Judge Paris of the Supreme Court of British Columbia to return it.



Wilbert Smith – Gravity Control (Anti - Gravity)

- Wilbert Smith, who became the Superintendent of Radio Regulations in Canada, postulated (in simple terms) that the force of Gravity was actually the result of interacting magnetic fields that objects themselves generated.
- He suggested that a “motional” magnetic field might be used to influence gravity and he and his team designed experiments to test this.
- It seems very unlikely that Smith would lie about his experimental results, or misinterpret them.





Eugene Podkletnov / Ning Lee



http://www.space.com/business/technology/anti_grav_000928.html

- In 2002, Boeing, approached Podkletnov to work with them on further research into blocking gravity.
- He has also done experiments with a “force beam” and weight reduction.
- Information is decidedly sketchy.
- Ning Li worked on a “Gravity Shielding Device” at U. of Alabama, but an article on space.com said:
- The main university professor involved with the project, Ning Li, has since left the school. She said she has founded a company in Huntsville that also will market a gravity-shield device.
- Li said she dropped the NASA collaboration and decided to work independently after the agency “wasted” the project's money and resources.

Coral Castle – Built Using Anti-Gravity Methods?

- This is a tourist attraction in Florida.
- It seems to have been built single-handedly by a Latvian immigrant, Edward Leedskalnin.
- Some of the blocks at Coral Castle weigh 30 tons, yet he seemed to have moved them without heavy lifting equipment.
- Statements he made and equipment at the site suggest he may have used Anti-Gravity techniques to construct it.
- This idea is not taken seriously, despite the difficulties in explaining the structures in any other way.

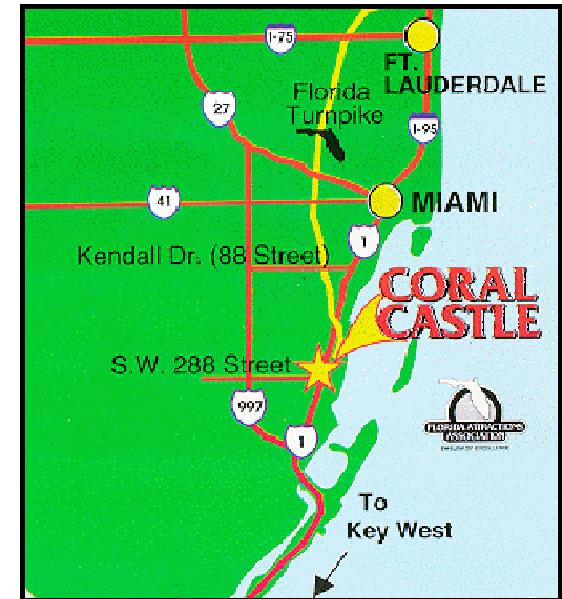

Black Projects - Research at Lockheed Martin - 1

- Some people seem to dismiss the idea that Anti-Gravity technology has been researched by US defence companies or the Air Force.
- In a documentary broadcast in 1999 on Channel 5, Boyd Bushman confirmed their research.
- Boyd Bushman also appeared to confirm that this research had produced results.
- Nick Cook of *Jane's Defence Weekly* spoke to him in about 1998.
- Bushman's words were:
 - "What we have is wonderful and it comes from miracles occurring, but that that we will see is not what we have."
 - "I am refining and heading towards something that all you have to do is charge and it is lifting up – it is losing weight."
 - "When we complete the technology, it should fly."



Secret US Projects?

- Over the last 50 years, there have been repeated stories and claims that the US has developed advanced craft, which seem to mimic some of the behaviour of the craft flown by “the people topside”.
- People like Bob Lazar are fairly well known in the field for these claims (Whilst Stanton Friedman does not believe Lazar’s claims, it is interesting to hear Boyd Bushman’s opinion... - Bushman gives Lazar some credit)
- Disclosure Project Witness, Mark McCandlish testifies to knowledge of ARV’s (Alien Reproduction Vehicles).
- Perhaps less well known is Edgar Fouché. He had top secret/crypto clearance and worked as an Engineering Programme Manager and Site Manager for US DoD contractors involved in classified development between 1987 and 1995.



Bob Lazar



Mark McCandlish



Edgar Fouché

Fouché in Area 51

- Edgar Fouché spoke to a number of people involved in Black projects – including people who piloted the SR-71 (Blackbird)
- Fouché describes a story of secretly being driven to an “unknown desert location” to work on Crypto equipment, in which he was an expert. But he knew this was somewhere near Groom Lake, where secret aircraft, such as the F-117 Stealth Fighter were tested.
- He states that, in the late 1970’s, when he had to fix some equipment, he came across and inspected a module labelled “Direct Orbital Code Link”, which contained advanced electronics. The meaning of this was confirmed in later conversations about satellite communications.
- He states he overheard conversations, while working there, about Quasi-Crystals which were an enabling technology for advanced communications and propulsion.



SR-71



F-117 Stealth Fighter

Fouché tells of More Advanced, Secret Aircraft

- Edgar Fouché describes a number of advanced aircraft.
- Even though the full specifications of the 30-odd year old SR-71 are still classified, it is known that it could fly at 85,000 feet at speeds up to Mach 3.3.
- The USAF now reportedly has the SR-75 which can travel at up to 120,000 feet and Mach 5 – Nevada ↔ Russia in 3 hours! This was part of **Project Aurora**.
- He describes SR-75 as a “launcher” for the SR-74, which can reach a height of 151 miles.
- SR-75 can also launch a 2-ton satellite payload.
- Fouché describes the Space Shuttle as an antique.
- He also describes 2 orbital vehicles - Space Orbital Nuclear – Service Intercept Vehicle (SON-SIV), code named *Locust*.



SR-75 may look similar to this



“A vintage piece Madam, have you had it valued recently?”

TR-3B – Secret USAF Craft - 1

- Fouché describes how he has seen photographs of a triangular craft called TR-3B, taken by someone who was giving Mission Support on a C-130.
- The TR-3B is thought to be part of the Aurora (Advanced Aircraft Development) programme.
- One of Fouché's associates states he saw the TR-3B at Papoose (part of Area 51). It hovered silently in the same position, for some 10 minutes, before gently settling vertically to the tarmac. At times a corona of silver blue light glowed around the circumference of the massive TR-3B.
- The operational model is 600 feet across.
- Fouché states that at least 3 of the billion dollar plus TR-3Bs were flying by 1994.
- The craft can travel at up to Mach 9 in any direction (due to reduced G-forces).

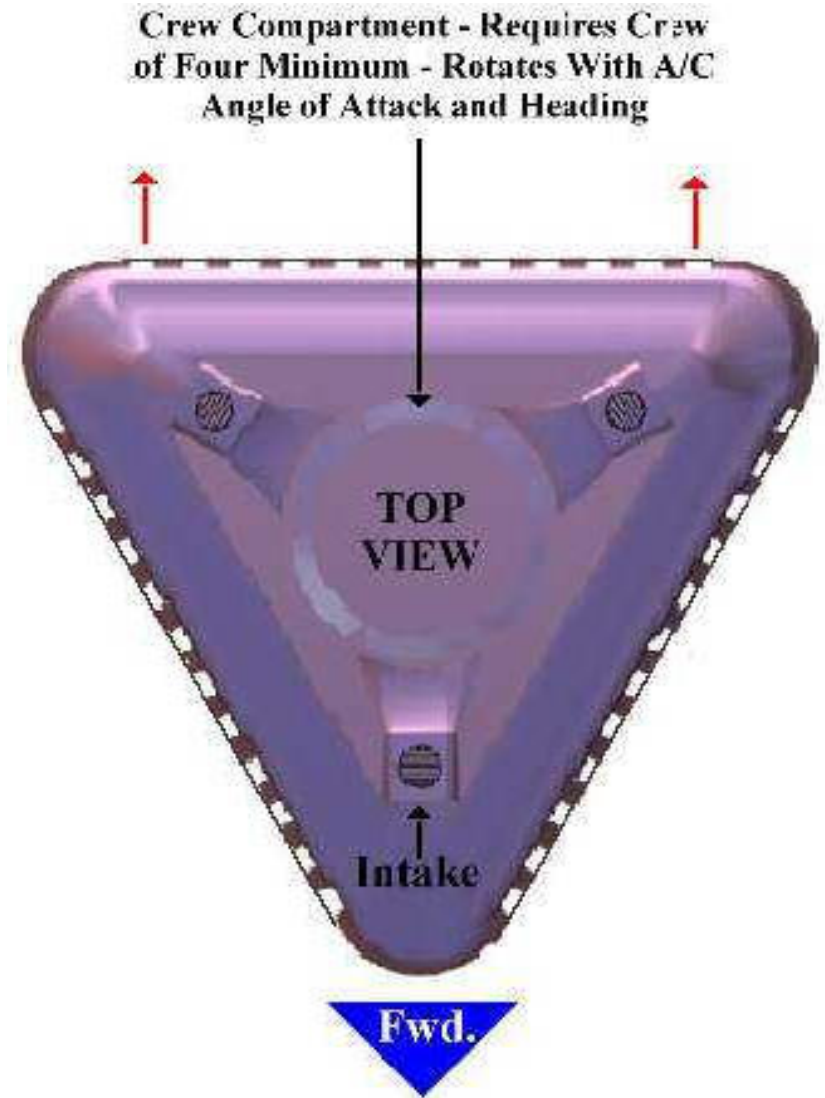

TR-3B – Secret USAF Craft - 2

- The TR-3B's outer coating is reactive and changes with radar stimulation and can change reflectiveness, radar absorptiveness, and colour.
- Quasi-Crystals are used in the vehicle's skin.
- Fouché describes part of the propulsion as being by Magnetic Field Disruption (MFD), which has been reverse engineered.
- Mercury based Plasma, pressurised at 250,000 atmospheres & at a temperature of 150K (-123°C) is **rotated at 50,000 rpm**.
- This reduces the weight of the centre of the craft by 89%. This increases manoeuvrability by 89% as well.
- Fouché states that MFD research had started as early as 1955.
- TR-3B uses Nuclear Thermal Hydrogen / Oxygen Engines for manoeuvring (technology mentioned by Fouché before recent NASA briefings – see later)

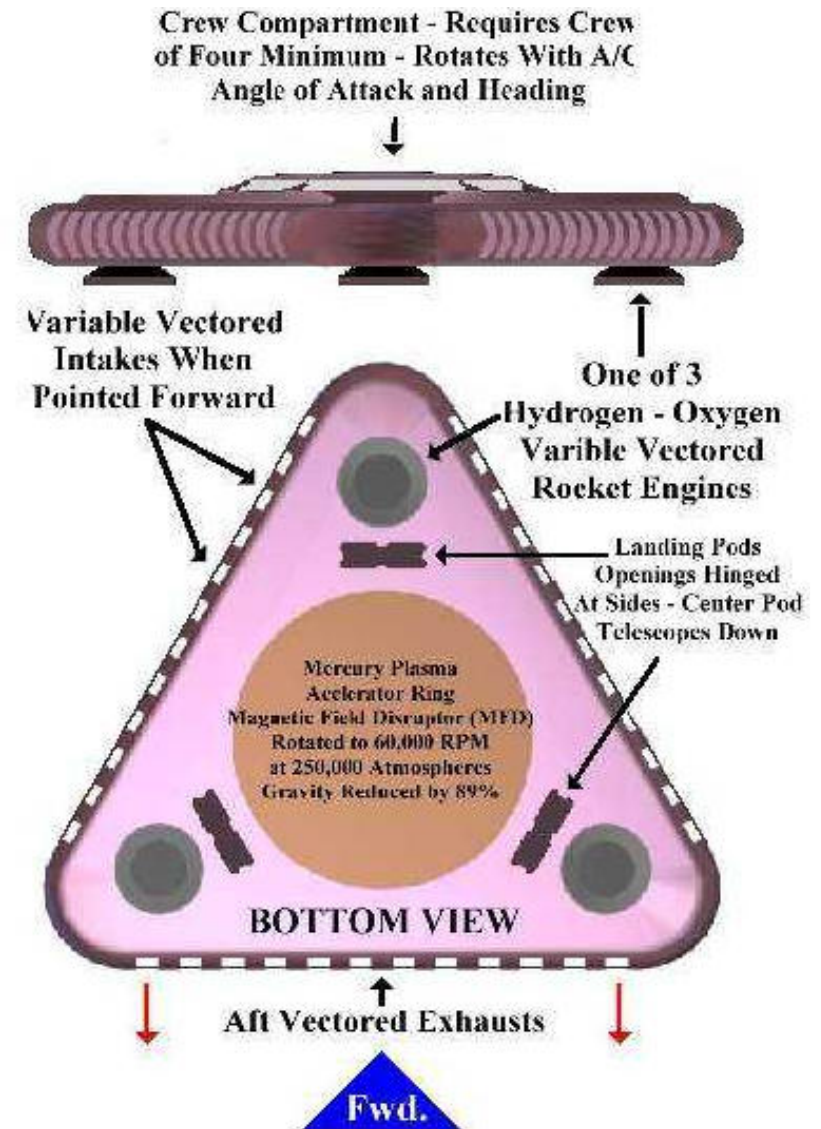

Results of the Research?

- Someone has suggested to me the following equation may give an answer to what has been produced by this research...

(Tesla + Thomas Townsend Brown)
x 30 years x ?billion dollars =

Spaceship!

- So now, let's review some history – and a connection which spans across history

The Quicksilver Connection...

- I am not the first to notice this, but here is a video that I made about it!
- Mercury seems to be important in antigravity techniques/technology...
- It is spoken of
 - ◆ in relation to the Nazi Bell Research
 - ◆ The TR-3B
 - ◆ In the Vaimanika Shastra – the ancient Indian Vedic text about Vimanas

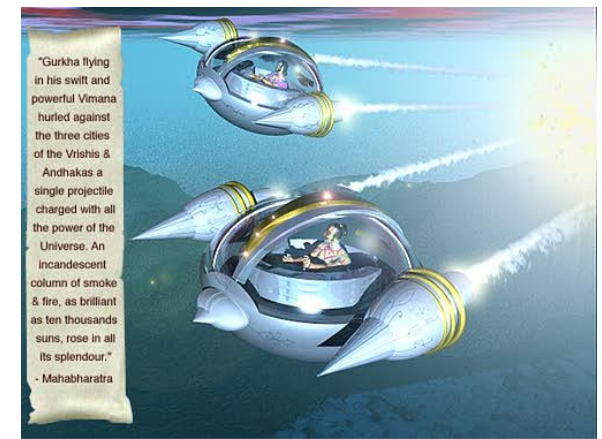
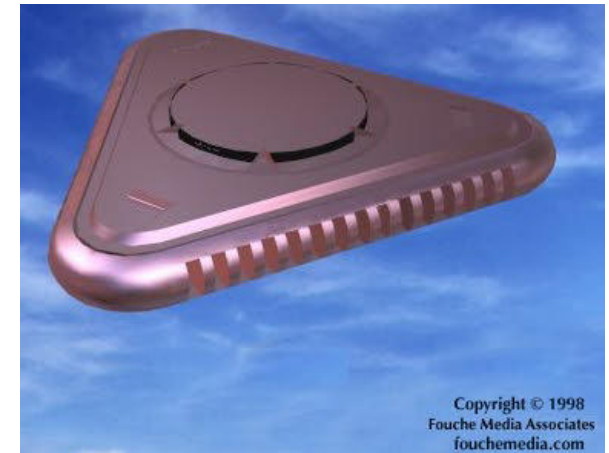

Flying Triangle Sightings

- Thousands have now been documented in a study by NIDS and other individual researchers such as Omar Fowler
- One was in the Sheffield Area in 1997
- One was in Cannock Chase, UK, Staffordshire in 2002
- http://ourstrangeplanet.com/index.php?option=com_content&task=view&id=65&Itemid=60



John Lenard Walson's Images

- No clear answers as to what these show.... (Find various videos on YouTube).
- A series entitled "Far Above Space and Time"



A Link Between Gravity and Magnetism?

- A NASA Science Story from 20th April 2004 talks of a new probe ...
- **“In Search of Gravitomagnetism Gravity Probe B has left Earth to measure a subtle yet long-sought force of Nature.”**

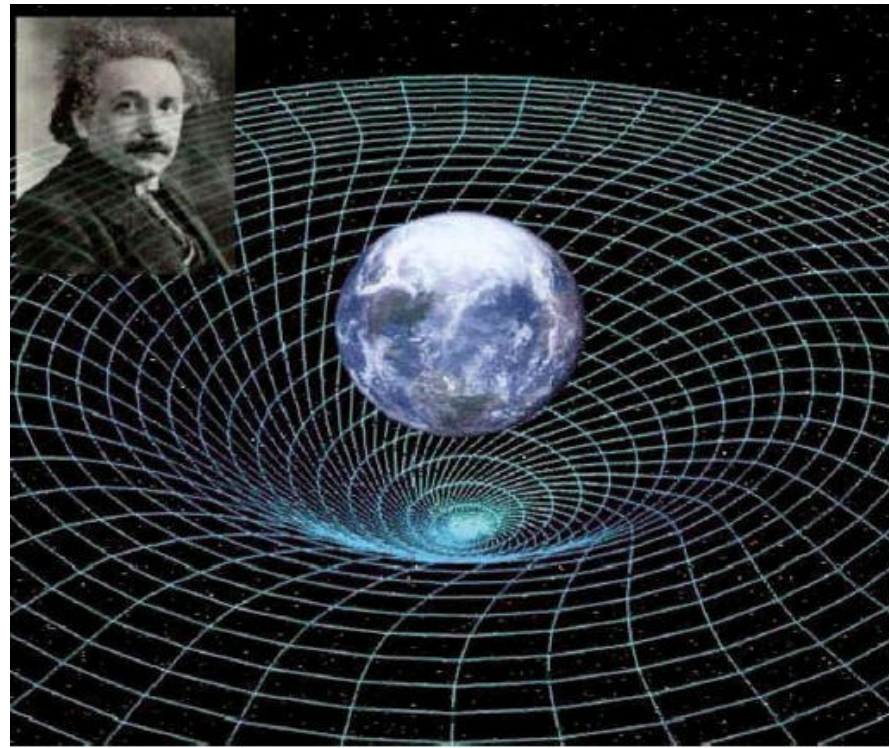
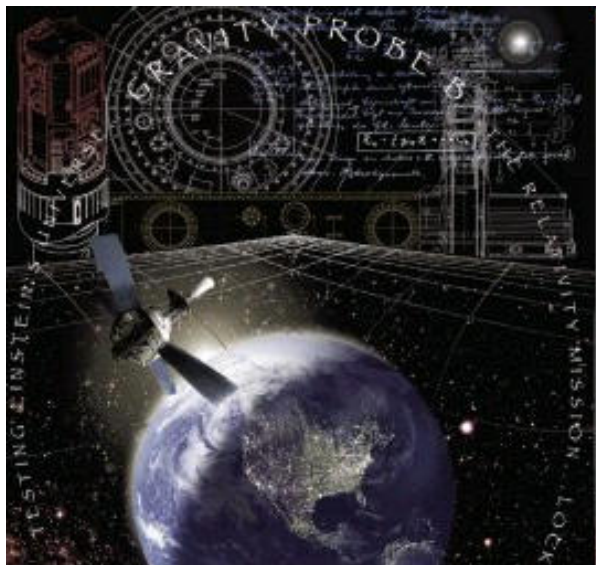

NASA Briefings on the New Mars/Moon Missions – 11th Feb 2004

- So where is this technology, and how much is there? Maybe General Les Lyles and General Tom Stafford know...
- Tom Stafford spoke on “Nuclear Electric” and “Nuclear Thermal Propulsion” – Edgar Fouché spoke of this in 1998!
- These hearings /briefings were deleted off the special website that was set up only a few months after they were posted
- Stafford was heard to say “The Air force does have a lot of technology...”
- I thought it was NASA that developed space faring technology?

So if there is something real in
all this...

Why the secrecy?

- ✓ Free energy for everyone (not allowed)
- ✓ Freedom for everyone who has the tech (not allowed)
- ✓ BUT Also...

IT'S ALREADY BEEN WEAPONISED AND USED...

What Technology Can do this?

- Steel turns to dust....



<http://www.drjudywood.com/>

What Technology Can do this?

- 80-90% if 2 of the worlds tallest buildings disappeared in 20 seconds... Where is the rubble?

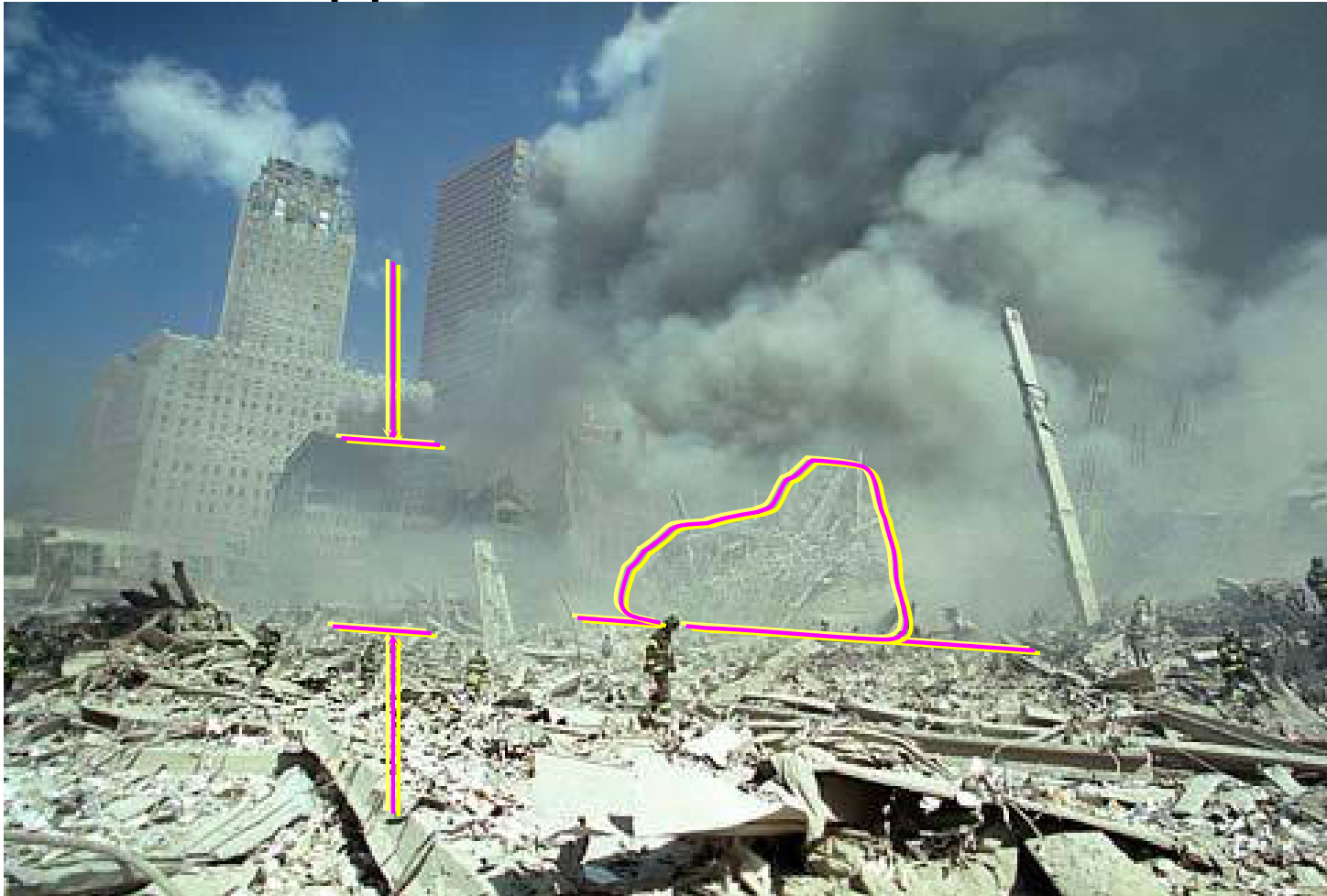

<http://www.drjudywood.com/>

Levitation Effects on 9/11

Dr Judy Wood has proposed that an undisclosed type of Directed Energy Weapon was used to destroy most of the World Trade Centre Complex on 9/11.



John Hutchison Levitation Demonstration 01 Nov 2008 – at his Vancouver Apartment



Shortly after 9/11 (How did the NYPD car get inverted?)

Bent Beams



See: <http://tinyurl.com/911hestudy/>

Jellification

See: <http://tinyurl.com/911hestudy/>

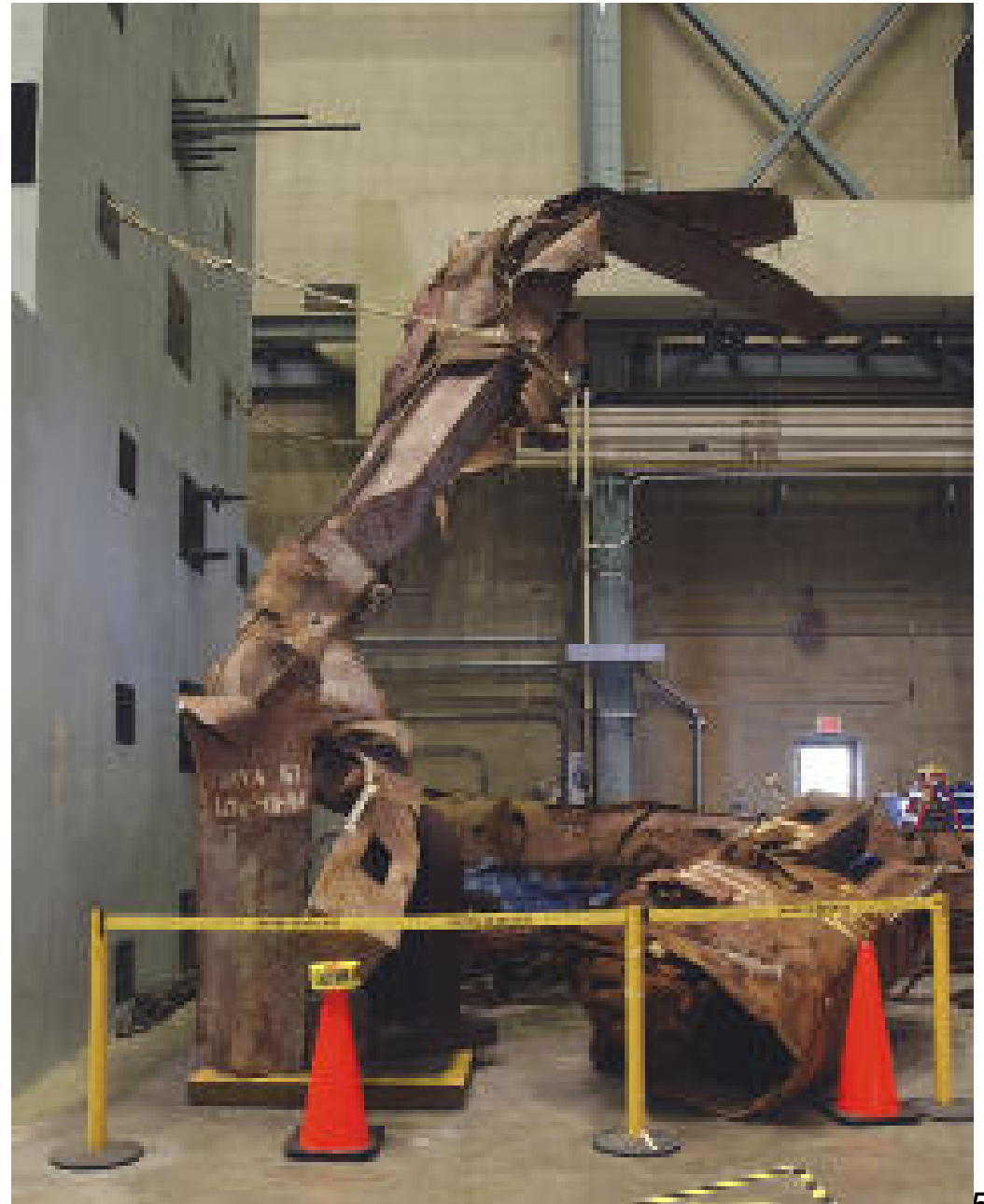
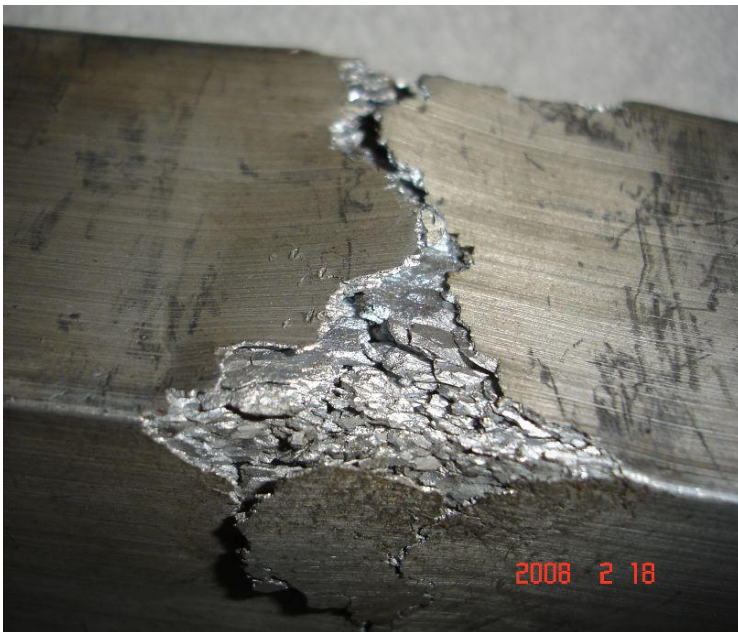

Levitation Effects on 9/11

See: <http://tinyurl.com/911hestudy/>

- **File no 9110506 - Michael Macko** (P4 - P5) I realized I couldn't get out from under the collapse. I dove under an ESU truck that was facing north on the west side of West Street. I dove under that and waited for the building to come down. When the building did come down, I actually thought I was trapped, and the truck was blown off me, pushed off me, I guess. It was not there. At that point I was just really shocked and didn't know what was going on at that point. I didn't know -- I was really, really shocked.)
- **File No. 9110075 - RENE DAVILA** - While we're walking I realize that we only have two people. I see my vehicle. The seats are covered. I've still got my bag. I hold it like a trophy. Like people collect basketballs. I haven't touched -- whatever the force was, it was so strong that it went inside of the bag.

The End

- In a story Thomas Townsend Brown once told to his family, he made an analogy, comparing a person and UFOs/ET craft to a fish looking up at the bottom of a passing ship.

"That fish looks up at that strange thing in his sky. It may have different properties, maybe size, prop wash or turbulence. Some fish will scatter and never look again, some fish will wonder, but none of them will really know what that form represents. They will never know about what other things man is capable of other than sailing across that particular part of the ocean. We in many ways are those fish, and the lights we see in our skies are the hulls of those ships."

Sources of Information

- JL Naudin's marvellous site <http://www.jlnlabs.org/>
- Nick Cook's *The Hunt For Zero Point (2002)* (Available from Amazon etc)
- American Antigravity <http://www.americanantigravity.com/>
- Archive of <http://www.teegeeack.com/ufo-tr3b-fs2002.html> (no longer available)
- Jeff Rense sound archives <http://www.rense.com/>
- <http://www.drjudywood.com/>
- UFO Casebook - <http://www.ufocasebook.com/>
- Fouche Presentation - <http://www.ufomind.com/misc/1998/aug/d26-001.shtml>
- Channel 5 Documentary *Billion Dollar Secret* (1999)
- Channel 4 Documentary *Welcome to the 11th Dimension* (2003)
- Channel 4 3-part Documentary *Riddle of the Skies* (1999)
- NASA Briefings at <http://www.moontomars.org/> (no longer available)
- Thomas Townsend Brown – <http://www.soteria.com/>
- Coral Castle – <http://www.coralcastle.com/>